

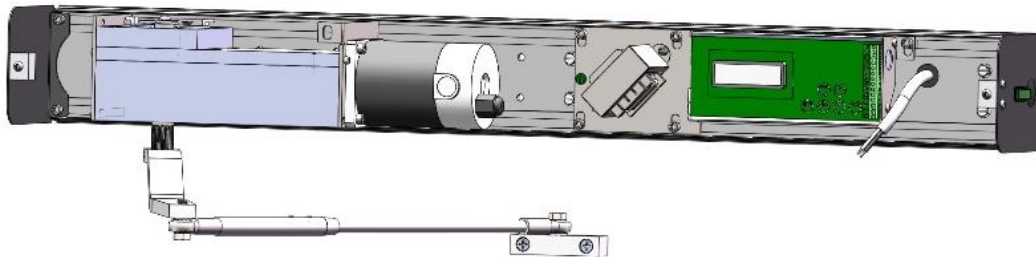

OAL-100 INSTALLATION INSTRUCTIONS



⚠ WARNING!

READ AND FOLLOW ALL INSTALLATION INSTRUCTIONS CAREFULLY!
FAILURE TO DO SO MAY RESULT IN PERSONAL INJURY OR PROPERTY DAMAGE!

AVOID ELECTRICAL SHOCK

DISCONNECT POWER DURING INSTALLATION

PLEASE READ ALL INSTRUCTIONS BEFORE INSTALLATION

POWER SUPPLY REQUIRED 115+/- 5VAC-60 HZ 0.4 AMPS

CONTROL BOARD POWER SUPPLY 16VDC

CONTROL BOARD TO BE GROUNDDED

KEEP FINGERS & CLOTHING CLEAR OF ALL MOVING PARTS

ADJUSTMENTS TO BE PERFORMED BY APPROVED TECHNICIAN ONLY

ALTERATION TO ANY COMPONENTS IS PROHIBITED

REMOVE ANY MECHANICAL DEVICES OR LOCKS THAT INTERFERE WITH THE OPERATION OF THE DOOR, (OTHER THAN PARTS INTEGRATED WITH THE OPERATOR SYSTEM)

OPERATOR TO BE INSTALLED 8 FEET MINIMUM ABOVE GROUND IF THERE ARE ANY EXPOSED MOVING PARTS



Table of Contents

Installation procedure	4
1. Replacement parts	5
2. General Information	6
2.1 Installation Instructions	6
2.2 Manual storage	6
2.3 omegaautomatics.com website	6
2.4 Dimensions	6
2.5 Building codes and standards	6
3. Product description	6
3.1 Intended use	6
3.2 Maximum deck weights	6
3.3 Hardware as shipped	7
3.3.1 Single swing door	7
3.3.2 Double swing door	7
4. Safety information	7
4.1 Safety Instructions	7
4.2 Safety warnings	7
4.3 Residual hazard	8
5. Recommended tools	8
6. Standard torque ranges	8
7. OAL-100 installation process	9
7.1 Unpack the box and take out cover	9
7.2 Installation of bottom track on the wall	9
7.3 Motor and control board wiring	10
7.4 Arm installation	11
7.4.1 Push arm application	11
7.4.2 Pull arm application	13
7.5 Programming (Basic)	14
7.6 Programming Heavy Duty (XP) operators	19
8. Trouble shooting	20



9. Universal Washroom Mode.....	21
9.1 Parameters.....	21
10. Access control mode.....	21
10.1 Parameters.....	21
11. Advanced setting	22
12. Terminal description	24
13. Re-Learn	24
14. Changes in software version	24
15. Programming encoder and parameters	25

Installation procedure:



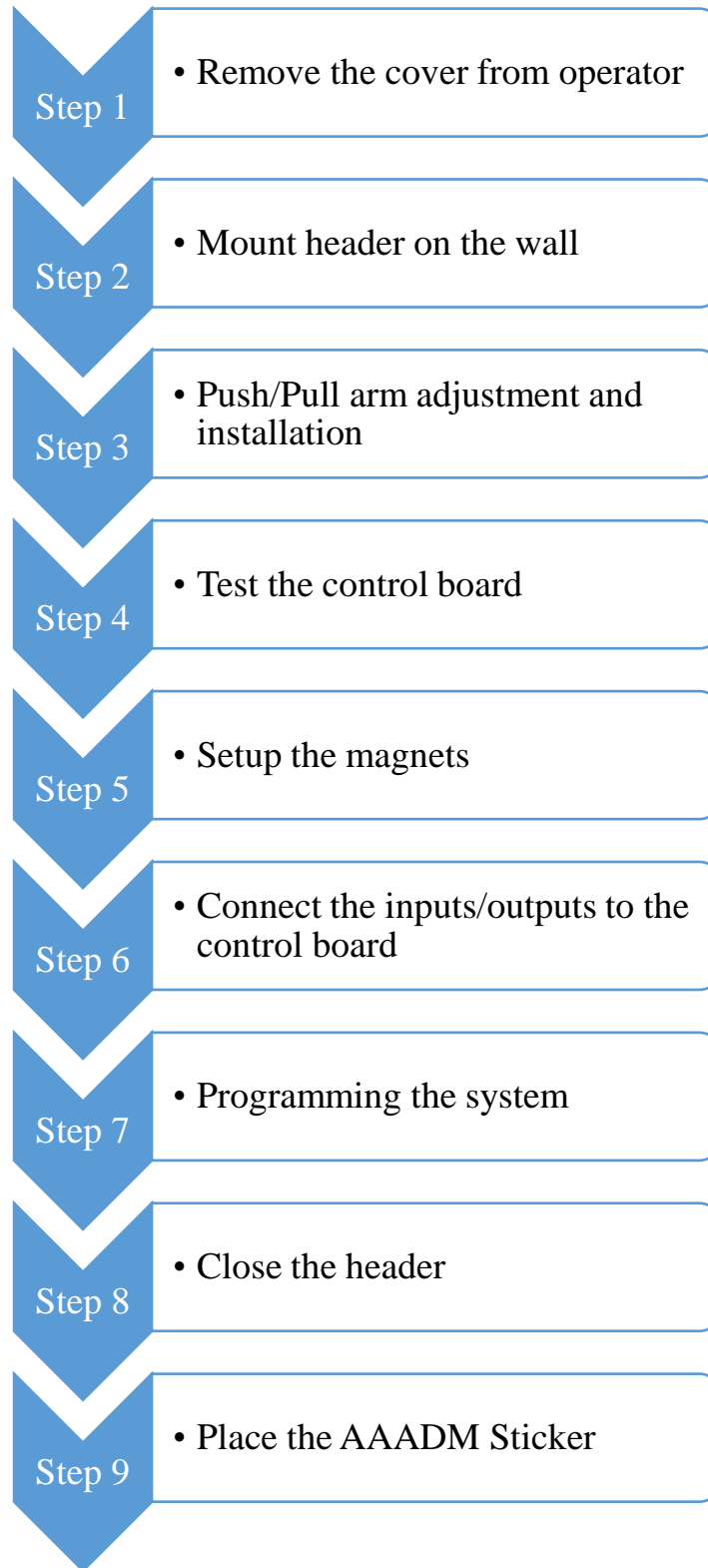

1. Replacement parts

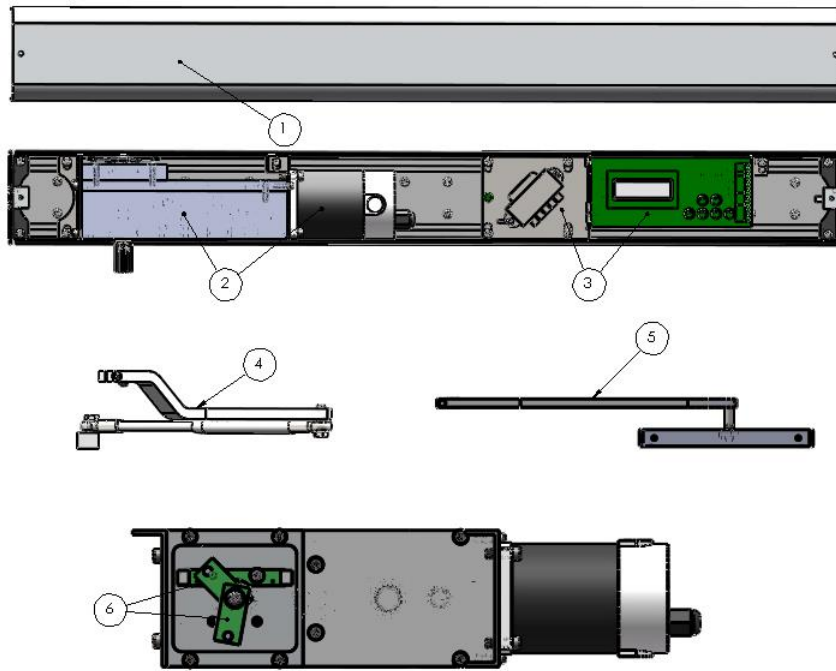

Fig 1.1

#	Category	Description	Part number
1	Swing door operator	OAL-100 cover 39" Clear	Ph-001-CL-39"
		OAL-100 cover 39" Dark Bronze	Ph-001-BZ-39"
		OAL-100 cover 41" Clear	Ph-001-CL-41"
		OAL-100 cover 41" Dark Bronze	Ph-001-BZ-41"
		OAL-100 cover custom size Clear	Ph-001-CL-Cust
		OAL-100 cover custom size Dark Bronze	Ph-001-BZ-Cust
2	Swing door operator	OAL-100 RH surface mount motor/gearbox	SM RH Gearbox with Motor
		OAL-100 LH surface mount motor/gearbox	SM LH Gearbox with Motor
		OAL-100 RH center spindle motor/gearbox	BL-CS-RH-Gearbox w/ Motor
		OAL-100 LH center spindle motor/gearbox	BL-CS-LH-Gearbox w/ Motor
		OAL-100 RH center hung motor/gearbox	BL-CH-RH-Gearbox w/ Motor
		OAL-100 LH center hung motor/gearbox	BL-CH-LH-Gearbox w/ Motor
		OAL-100XP RH surface mount motor/gearbox	SM RH Gearbox with Motor XP
		OAL-100XP LH surface mount motor/gearbox	SM LH Gearbox with Motor XP
		OAL-100XP RH center spindle motor/gearbox	BL-CS-RH-Gearbox w/ Motor XP
		OAL-100XP LH center spindle motor/gearbox	BL-CS-LH-Gearbox w/ Motor XP
3	Swing door operator	Control panel with 16V transformer	Control Panel 16V
		Control panel with 16V transformer and potentiometer	Control Panel 16V w/POT
		Control panel with 18V transformer	Control Panel 18V
		Control panel with 18V transformer and potentiometer	Control Panel 18V w/POT
4	Swing door arms	Push arm kit clear	Push Arm-CL
		Push arm kit Black	Push Arm - Black
5	Swing door arms	Pull arm kit clear with 10" track	Pull Arm - 10" CL
		Pull arm kit clear with 24" track	Pull Arm - 24" CL
		Pull arm kit black with 10" track	Pull Arm - 10" BL
		Pull arm kit black with 24" track	Pull Arm - 24" BL
6	Swing door sensors	OAL-100 sensor set	Pg-011

2. General Information

2.1 Installation Instructions

This manual provides installation instructions for OAL-100 automatic swing door operators used in Single door and pair door installations.

2.2 Manual storage

This document must be kept in a secure place, and accessible for reference as required. If the door system should be transferred to another facility ensure that this document is transferred as well.

2.3 omegaautomatics.com website

Manuals are available for review, download, and printing on the omegaautomatics.com website.

2.4 Dimensions

Unless otherwise specified, all dimensions are given in inches (")

2.5 Building codes and standards

OAL-100 installation: observe applicable national and local building codes

3. Product description

3.1 Intended use

The OAL-100 is electromechanical operators used exclusively for opening and closing interior or exterior swing doors. The OAL-100 operator installed in a surface mount header at customer site. The header must be installed on an interior building surface. For double swing doors, both operators are installed in a single header.

- ❖ To reduce risk of injury to persons, use this OAL-100 operator only with automatic Swing doors that the operator is designed for Reference Chapter 6, Technical data.

3.2 Maximum door weight

OAL-100: 250 pounds (113.398 kg) at 48" door width.

*Based on prevailing conditions at the door opening.

3.3 Hardware as shipped

3.3.1 Single swing door

1. Box containing surface mount header assembly for one OAL-100 operator. Included inside header:

Surface Mount	OHC (Over Head Concealed)	In Ground
Motor Gearbox	Motor Gearbox (Spline/ Square spindle)	Motor Gearbox
Control Board	Control Board	Control Board
Arm Assembly Kit	Center Spindle Arm Assembly Kit	Square Spindle Jockey Box
	Center Hung Top Arm	Bottom Arm

3.3.2 Double swing door

1. Box containing surface mount header assembly for two OAL-100 operators. Included inside header:

Manual and Auto (Surface Mount)	Manual and Auto (OHC or In Ground)	Double Auto
1 Motor Gearbox	Motor Gearbox (Spline/ Square Spindle)	2 Motor Gearboxes
1 Control Board	Manual Door Closer Dorma RTS 88	2 Control Boards
2 Arm Assembly Kits	Center Spindle Arm Assembly Kit or Center Hung Top Arm	2 Arm Assembly Kit (depends on the type of the operator)
Mount Plate for Manual Door Closer (LCN4040)	In Ground Bottom Arm	

4. Safety information

4.1 Safety Instructions

This document contains important instructions for installation of the OAL-100 swing door operators. Renew these instructions thoroughly prior to installation and follow them carefully during installation commissioning, troubleshooting and maintenance.

4.2 Safety warnings

- ❖ Damage to equipment or incorrect equipment operation may result from an incorrect installation.
- ❖ Hazard to mechanical processes by use of control settings elements or procedures not documented in this manual!
- ❖ Electric shock hazard!

- ❖ By use of control elements, settings of Procedures not documented in this manual!
- ❖ Work on electrical equipment and 115 VAC wiring installation must be performed only by qualified personnel!
- ❖ Metallic doors must be grounded per national and local codes!
- ❖ Hand pinch point and crushing hazards of door closing edges!
- ❖ Crushing hazards at door closing edges!

4.3 Residual hazard

- ❖ After installation, hazards such as minor crushing, impact with limited force, and risk to unsupervised children may exist depending on structural design of door area, type of door, and any safeguards that have been implemented.
- ❖ Hand pinch point and crushing hazards at arm and track!

5. Recommended tools

- 1- 1/8 Allen key
- 2- 1/4 Allen key
- 3- 3/16 Allen key
- 4- 5/64 Allen key
- 5- 0.3 mm Flat screwdriver
- 6- 9/16 Wrench
- 7- Ph3 Screwdriver
- 8- Drill/ Drill bits
- 9- Torque wrench
- 10- Appropriate screws for application
- 11- Pressure gauge (0-35 lbf)

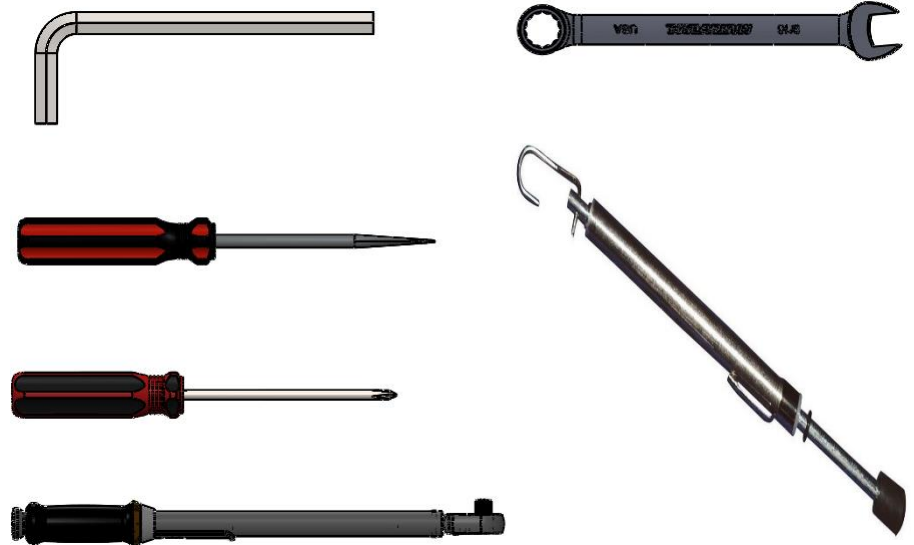

Fig 5.1

6. Standard torque ranges

Fastener size	ft lb
M5- #10	3.7
M6- 1/4	7
M8- 5/16	17
M10- 3/8	34
M12- 1/2	58

7. OAL-100 installation process

7.1 Unpack the box and take out cover

- ✓ Use 1/8" allen key to take out cover screws

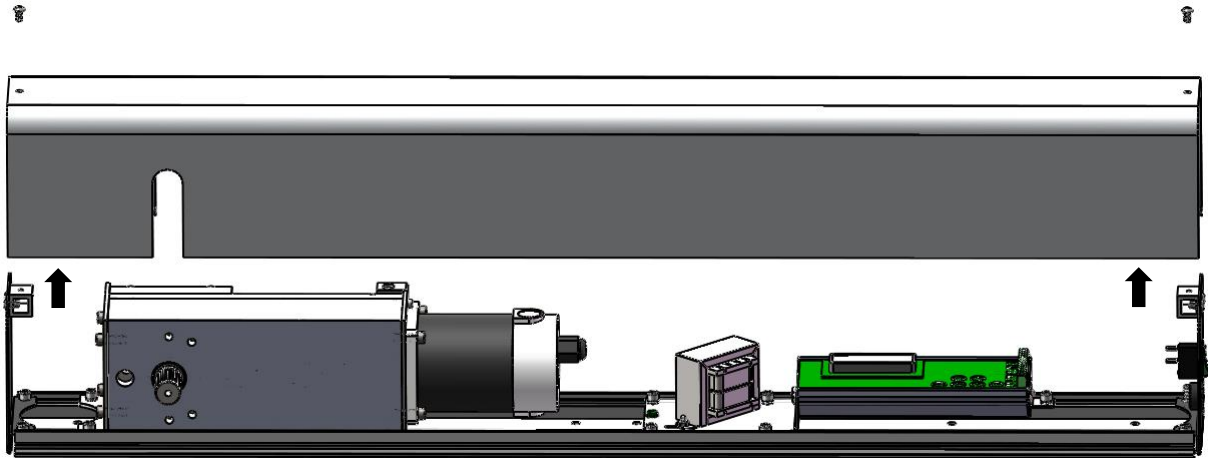

Fig 7.1.1

7.2 Installation of bottom track on the wall

- ✓ Mark the location of the motor on back plate
- ✓ Use 1/4" allen key to take out gearbox fasteners and remove gearbox
- ✓ Use 1/4" allen key to take out controller fasteners and remove controller

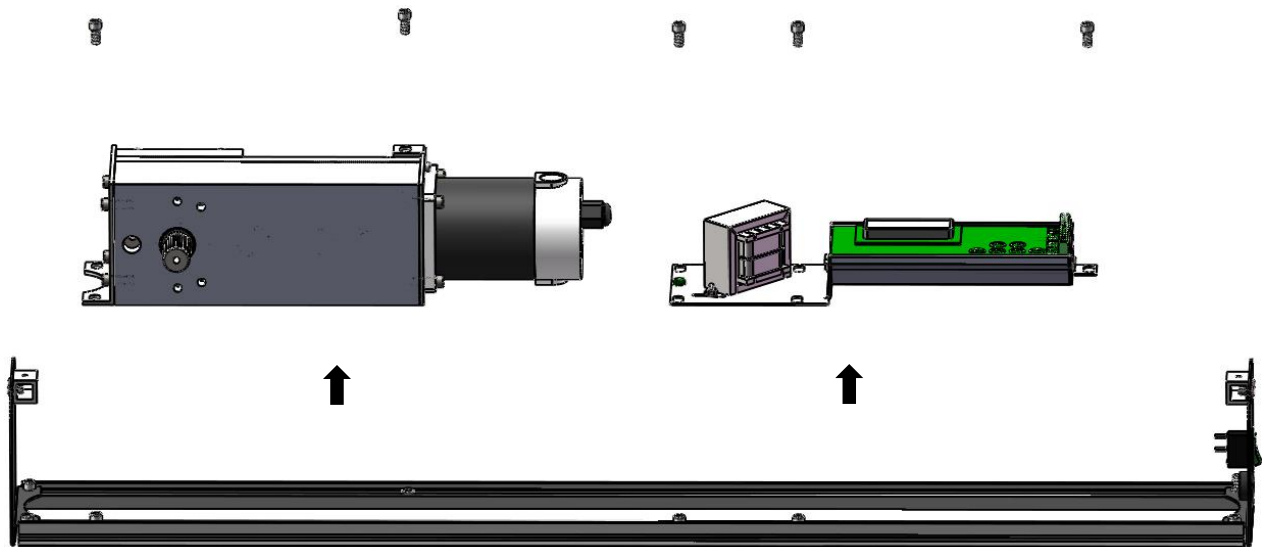

Fig 7.2.1

- ✓ Use drill with drill bit that matches screw size to drill for mounting screws.

- ✓ Always drill between channels
- ✓ Drill at least 6 holes on gearbox side and 4 on controller side

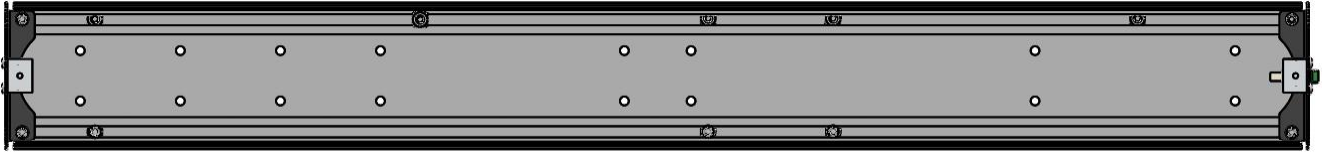

Fig 7.2.2

- ✓ For push application mount the unit bottom flush with the bottom of the frame
- ✓ For pull application mount the bottom of the unit on top of the frame (2" above the top of the door).

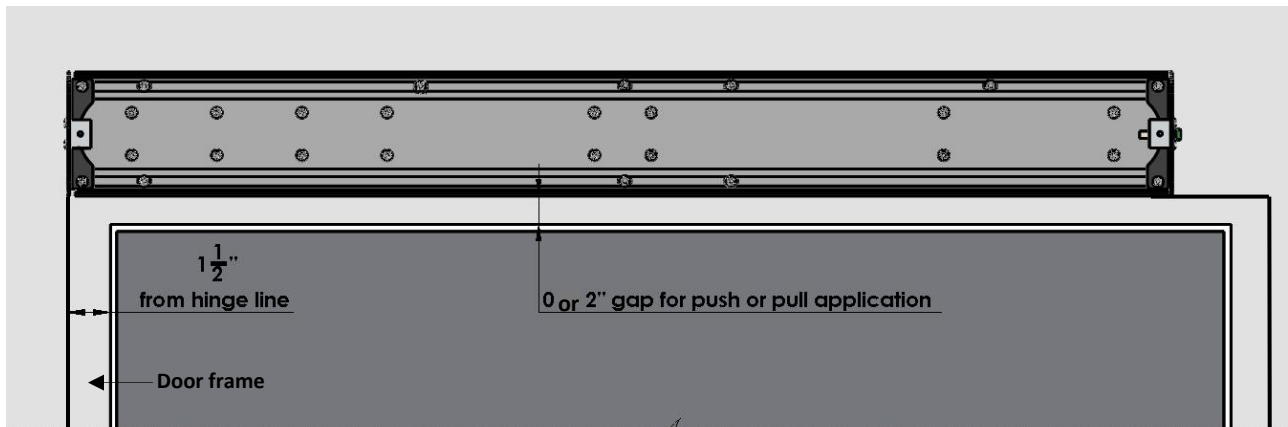

Fig 7.2.3

- ✓ Install the gearbox aligned with marks using appropriate fasteners.
- ✓ Install control board on back plate using appropriate fasteners.

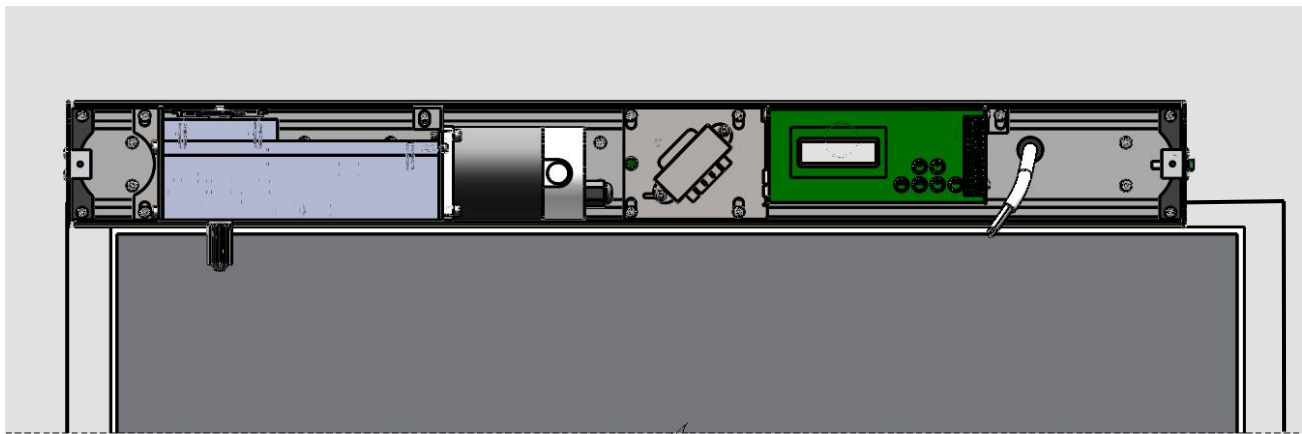

Fig 7.2.4

7.3 Motor and control board wiring

- ✓ Connect motor wire to motor connector on controller.
- ✓ Connect limit switch wire to limit connector on controller.

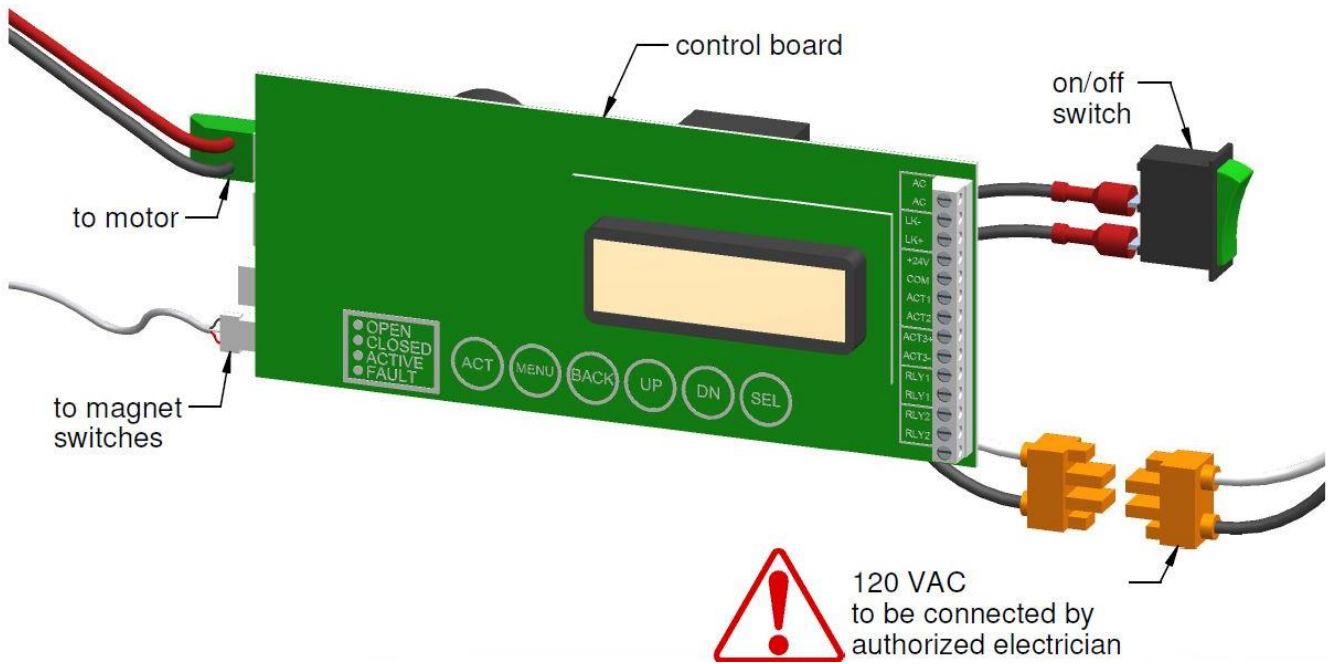

Fig 7.3.1

7.4 Arm installation

7.4.1 Push arm application

- ✓ To install arm on door operator the unit should have 110 VAC power.
- ✓ Add jumper wire on terminals COM and ACT 2

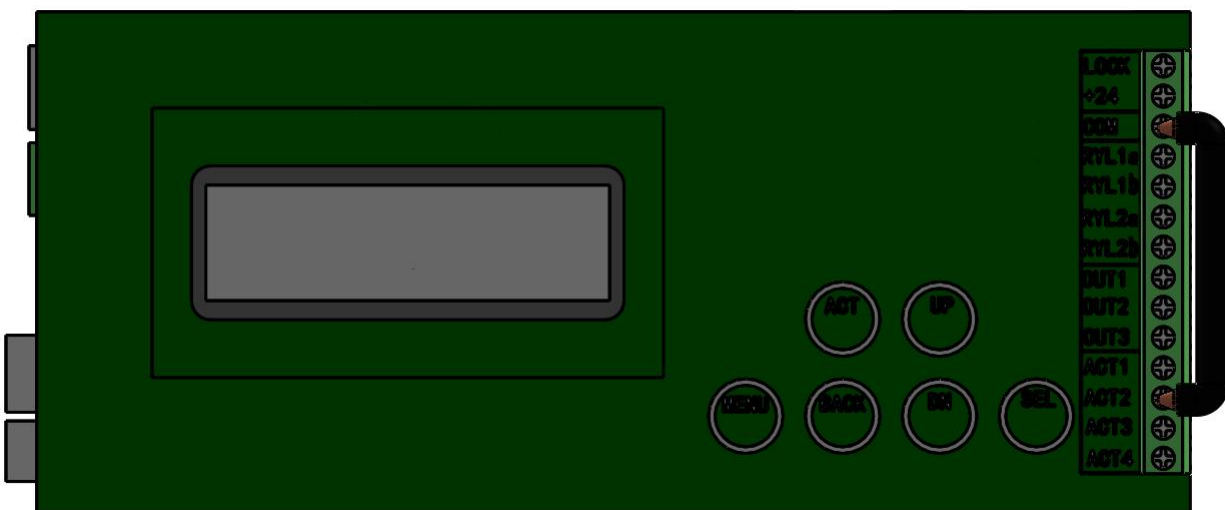

Fig 7.4.1.1

- ✓ Turn the unit on and allow it load the gearbox all the way to hard stop.
- ✓ If the power is not provided, use the arm to manually load the gearbox to hard stop by turning it until hard stop is reached. Lock the gearbox with metal rod through one of the 1/2" diameter holes at bottom of the gearbox.

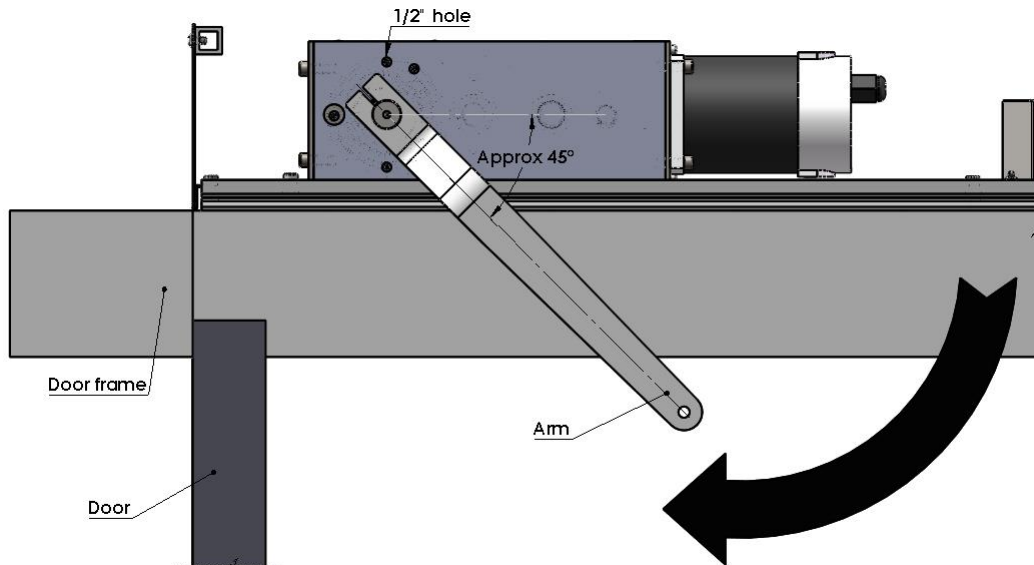

Fig 7.4.1.2

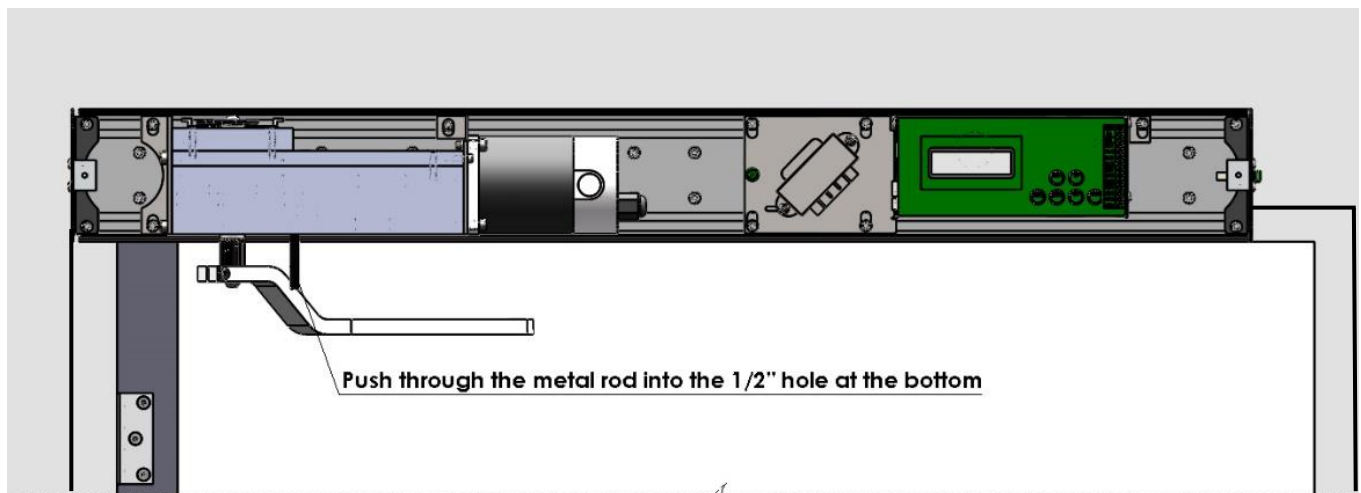

Fig 7.4.1.3

- ✓ Set the door to stay open at desired angle.
- ✓ Attach arm to spindle approx. 45° on door frame. Fasten 3/16 socket screw on arm
- ✓ Level the rod and attach the block on the arm to the door.

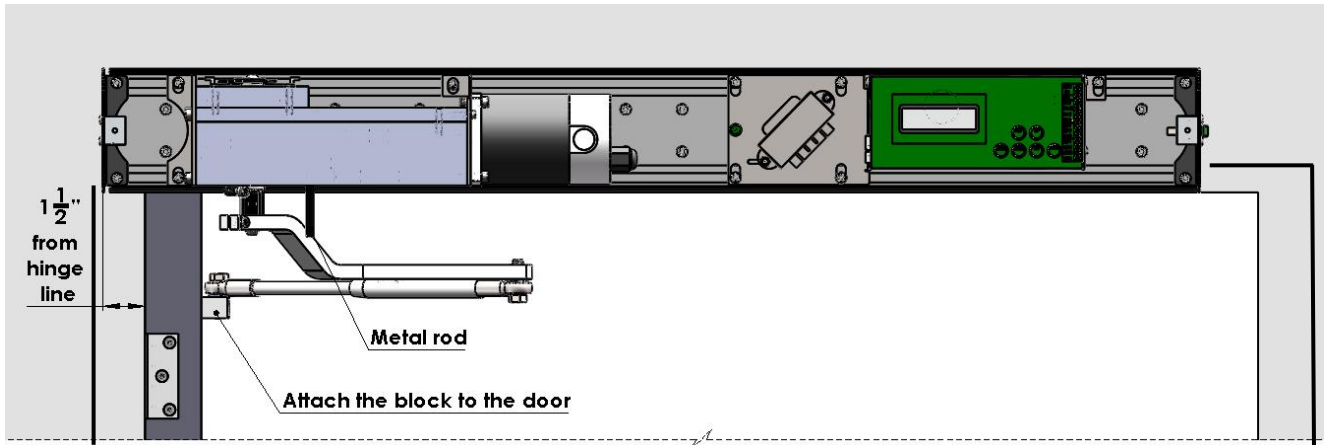

Fig 7.4.1.4

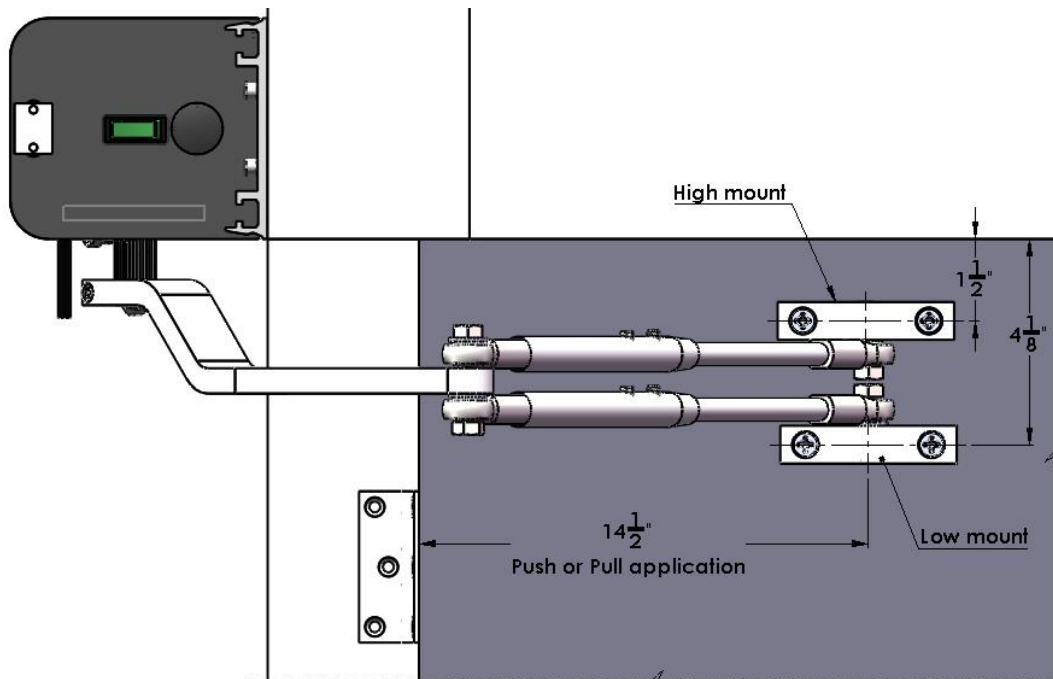

Fig 7.4.1.5

- ✓ Push the door slightly to release the locked rod from gearbox, if loaded using power then remove jumper wire from terminals com and ACT 2.
- ✓ The door should work as it has a manual closer.
- ✓ Attach the PH3 screw with safety washer on bottom of spindle.
- ✓ Door operator is now installed and ready for programming.

7.4.2 Pull arm application

First of all, the operator needs to reach the hard stop itself (by adding a jumper wire like Fig 7.4.1.1) or manually with the pull arm. In the next step push the rod into gearbox (same as Fig 7.4.1.4) to stop it, then open the door to your desired fully open position and attach the pull arm to the spindle (Fig 7.4.2.1). In the last step, take out the rod and release the arm to reach the fully close position.

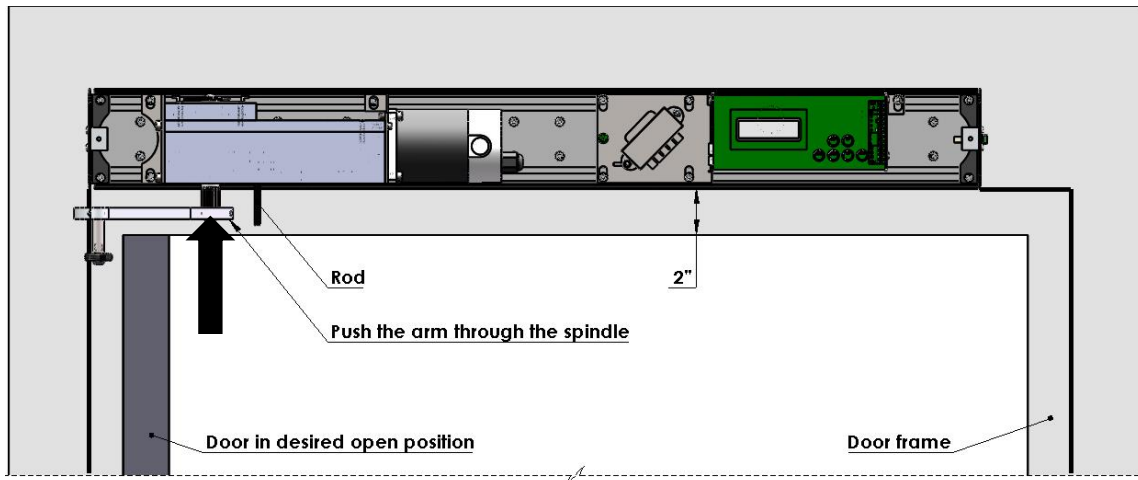

Fig 7.4.2.1

Now, you can follow the below process:

- ✓ Keep the door close
- ✓ Install the track on top of the door same as the following dimensions

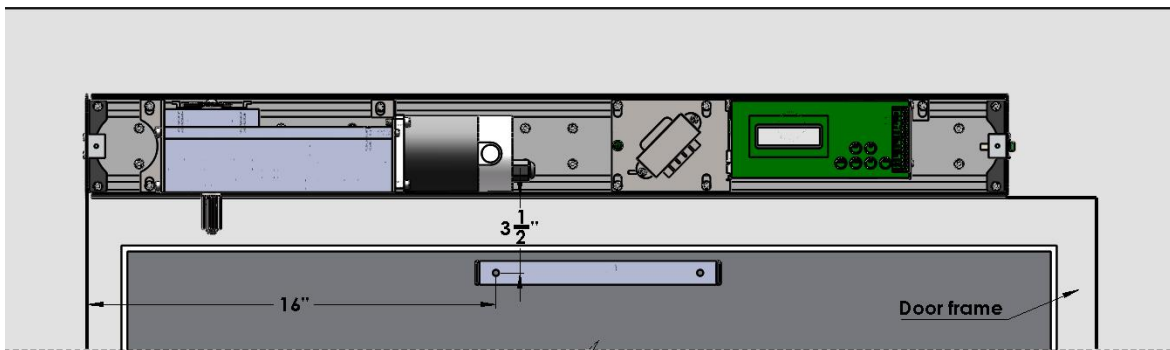

Fig 7.4.2.2

- ✓ Slide the roller into the track and push the arm through the spindle then tight the screw with washer at the middle of spindle

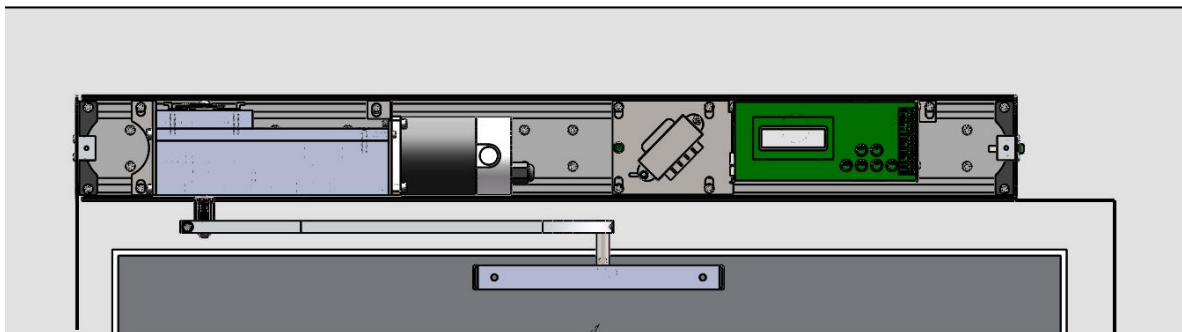

Fig 7.4.2.3

7.5 Programming (Basic)

- ✓ Setting door position switches.
- ✓ Refer to image how the top magnetic switches on gearbox should be set up

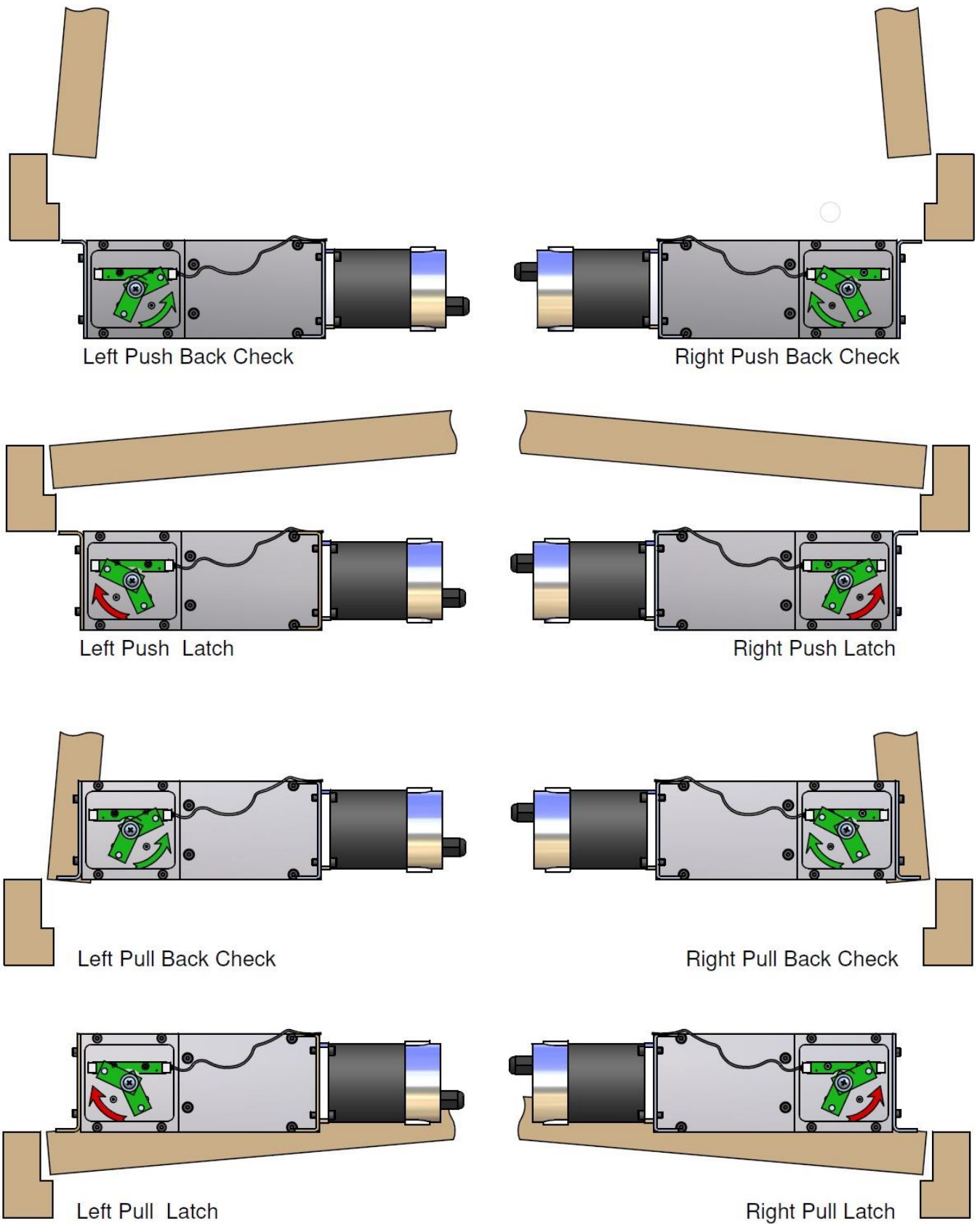

Fig 7.5.1

- ✓ Before accessing menu door needs to be fully closed and door operator control display should say door closed

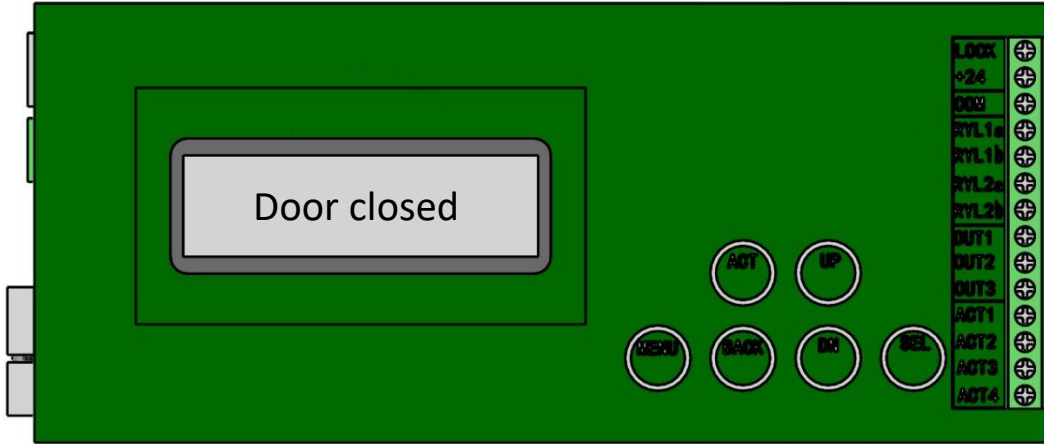

Fig 7.5.2

- ✓ Press menu touch button

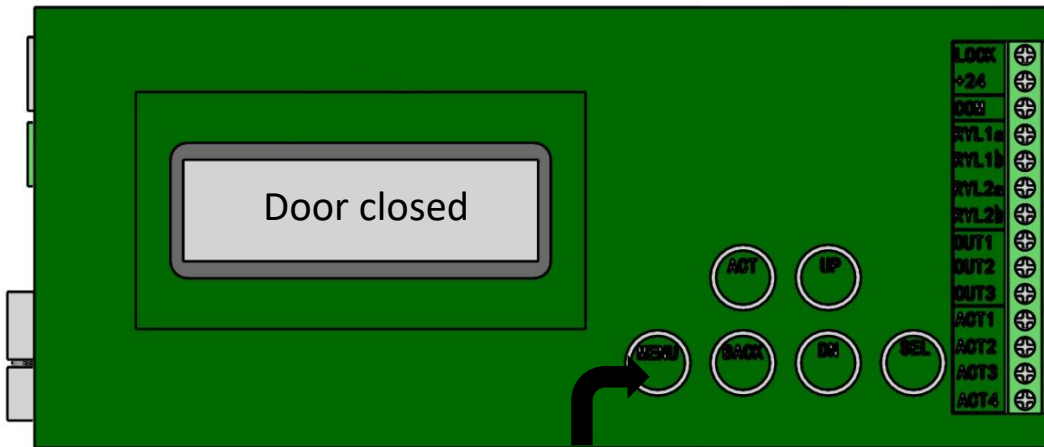

Fig 7.5.3

- ✓ Press SEL touch button to access parameters.

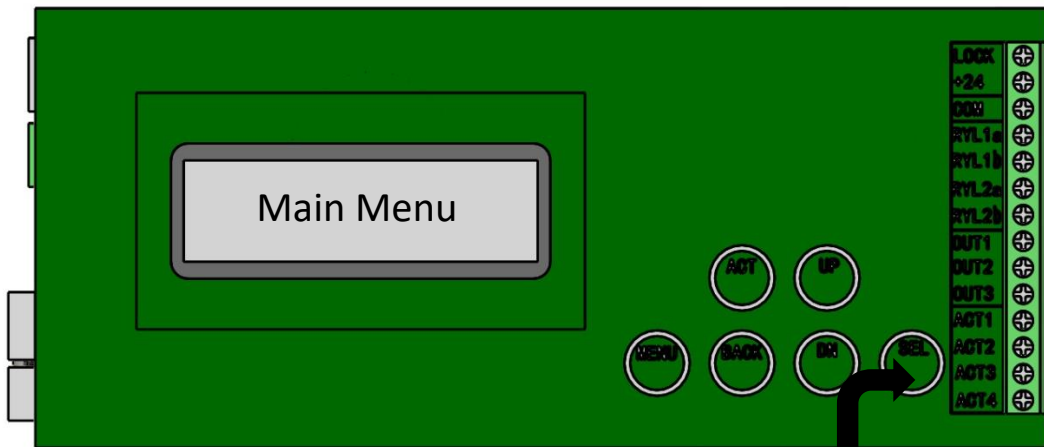

Fig 7.5.4

✓ Refer to table for setting parameters.

Display Text	Default Value	Min Value	Max Value	Step Size	Parameter Description
Overload	50	5	99	5	Extra amount of force the controller can exert if the door encounters an obstruction before triggering overload protection. (Unit %)
Activate Dly	0	0	20	1	Delay between receiving activation signal device to door opening. (Unit 0.5sec)
Holding Time	6	0	99	1	Time door stays open. (Unit sec)
Backchk Spd	35	0	60	5	Speed/power with which door travels after backcheck is achieved. (Unit %)
Opening Spd	55	0	99	5	Speed/power at which door opens. (Unit %)
Closing Spd	35	0	99	5	Speed/power at which door closes. (Unit %)
Latching Spd	50	0	99	1	Speed/power at which door closes after achieving latch position. (Unit %)
Control Mode	1	1	3	1	Operating Mode 1 - Regular Mode 2 - Washroom Mode 3 - Access control Mode
Power Assist	0	0	1	1	When pushed manually door will open with help of motor 0 - Disabled 1 - Enabled
Pwr Ast Time	3	0	20	1	Time door stays open when opened with power assist. (Unit sec)
Reactivate	1	0	1	1	Door will reactivate when it receives a valid ACT signal at any time 0 - Disabled 1 - Enabled
Closing Time	50	0	50	1	Time after which the Closing cycle times out. (Unit sec)
Opening Time	50	0	50	1	Time after which the Opening cycle times out. (Unit sec)
Latch Time	2	0	10	1	Time after which the Latching cycle finishes. (Unit sec)
Ramp Time	1	1	10	1	Time in which the door ramps up to max the opening speed. (Unit sec)
Disp Timeout	30	1	60	1	Time before the display times out. (Unit sec)
Cycles	0	-	-	-	Number of times the door has cycled. Read only.
Pwr Cls Time	0	0	10	1	How long the door tries to close under motor power. Also sets Power Latch Time when used with an Encoder (Unit sec)
Pwr Cls Spd	25	0	99	5	Speed/power at which door closes using Power closing. Also sets Power Latch Speed when used with an Encoder (Unit %)
Preload Time	0	0	5	1	How long the door pulls in before opening. Used with Encoder. (Unit sec)
Preload Spd	25	0	99	5	Speed/power at which door pulls in before opening. Used with Encoder. (Unit %)

Display Text	Default Value	Min Value	Max Value	Step Size	Parameter Description
Act Hld Time	0	0	15	1	Minimum length of time the ACT1 signal must stay active to activate the door. (Unit sec)
Hold Open	0	0	1	1	Ratcheting mode; Need to press button to open, then again to close 0 - Disabled 1 - Enabled
Latch Type	1	0	1	1	Type of Latch brake. 0 - Unpowered (Faster) 1 - Powered (Slower)
Fsec0 Fsafe1	0	0	1	1	Type of door strike connected 0 - Fail Secure; Door locked when no power applied 1 - Fail Safe; Door unlocked when no power applied
Sensor Cfg	0	0	2	1	How many being used safety sensors are being used 0 - No sensors connected 1 - Approach and Swing and Bodyguard Sensor 2 - LZR Approach and Swing Sensors
Easy Open	1	0	1	1	Helps manually open a door with encoder. 0 - Disabled 1 - Enabled
Fact Reset	0	0	1	1	Factory Reset. Set to 1 to restore factory defaults.
Backchk Pos	20	5	40	5	Backcheck Position. Used with Encoder. (Unit degrees form fully open position)
Latch Pos	10	5	15	1	Latch Position. Used with Encoder. (Unit degrees form fully closed position)

- ✓ Once parameters are set the door operator is ready for learning cycle.
- ✓ Check the doorway for any obstacles and make sure that the door close and open smoothly.
- ✓ Check if the door is fully closed and display shows door closed press the ACT touch button.

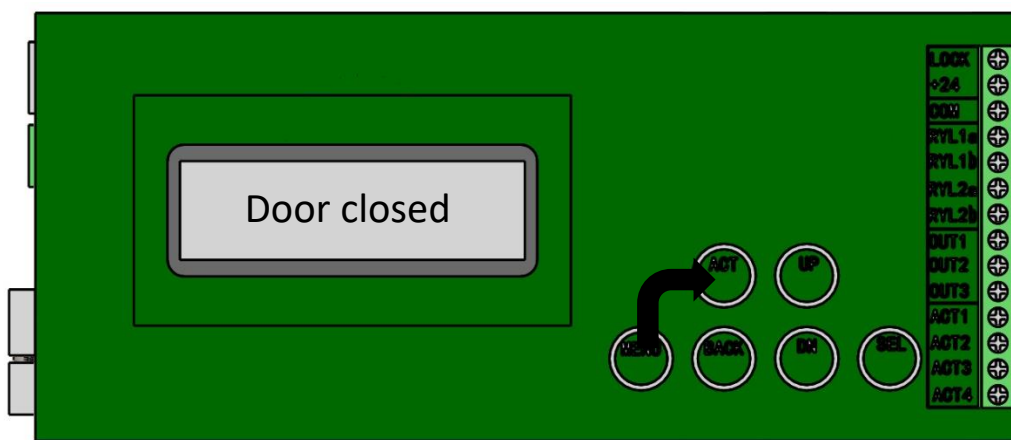

Fig 7.5.5

- ✓ The display will show “door opening”.

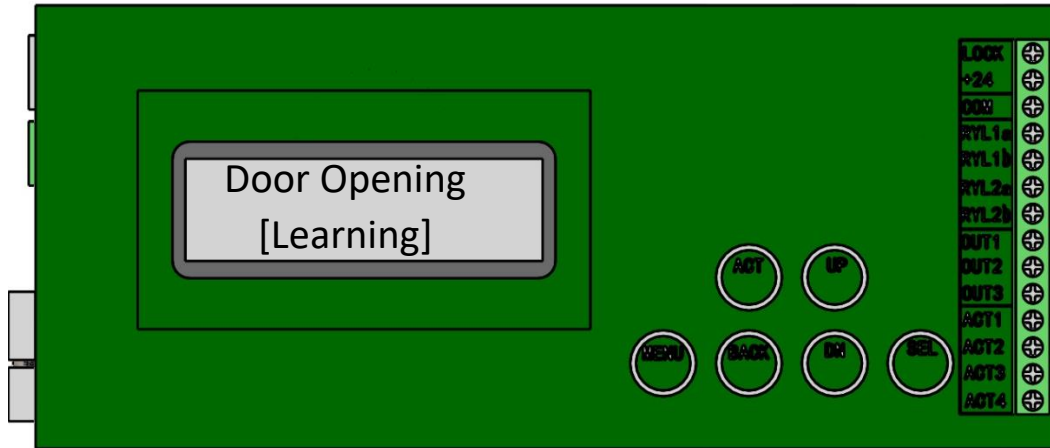

Fig 7.5.6

- ✓ The learning cycle does not register obstruction. Make sure that the path of the door is clear from obstacles.
- ✓ Once the learning cycle is completed and the door is in closed position the door operator is programmed.
- ✓ Connect activating device and run multiple test cycle to assure proper operation.

7.6 Programming Heavy Duty (XP) operators

- ✓ After you follow the abovementioned steps of installation of the push or pull arm application, turn on the operator then control board should recognize the encoder.
- ✓ Press MENU touch button then press down touch button to see “Calibrate”.

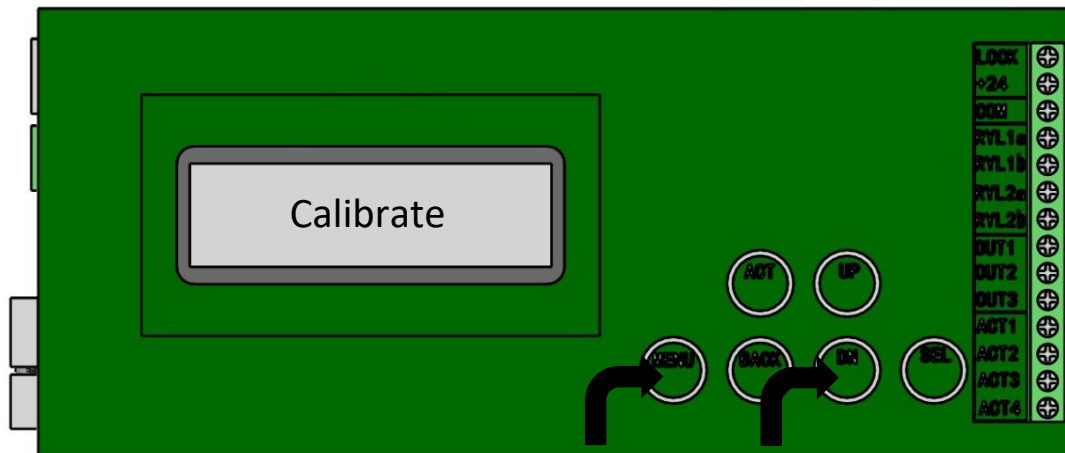

Fig 7.6.1

- ✓ Then press the SEL touch button.
- ✓ Screen shows “Hit ACT to begin”.
- ✓ Press ACT button and manually push the door to the maximum opening position.

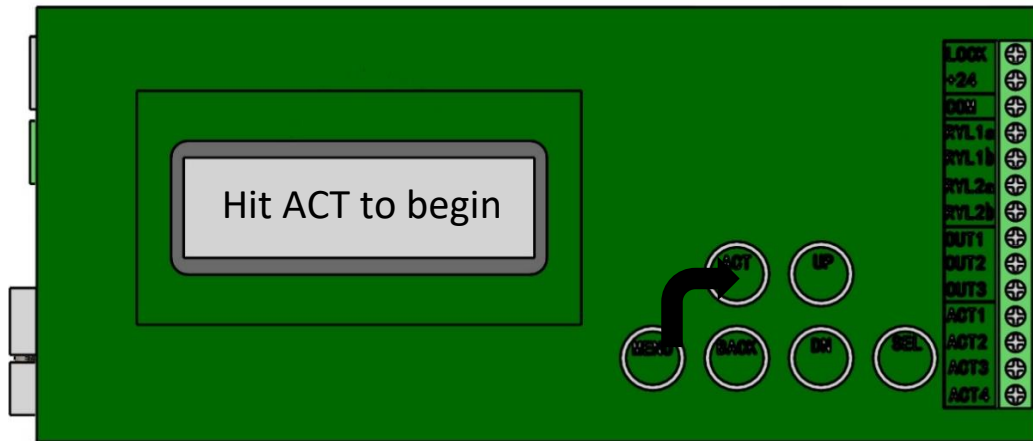

Fig 7.6.2

- ✓ Then release the door to close on its own.
- ✓ The value on the screen should be around 100 ± 8 .
- ✓ Press SEL button to save the settings.

You can activate the door and scroll through parameters to make adjustments as needed to Backcheck Speed, Overload, Holding Time etc. as needed for your installation.

You can access to our YouTube channel to watch the sample installation videos with the following link.

https://www.youtube.com/channel/UCI2d_nzMlxHzSmhMQY_e3Fg/featured

8. Trouble shooting

Possible problems	Possible solutions
Door does not open	-Check the power -Check the ON/OFF switch -Check the activation devices connection -Check the display message
Display does not indicate door closed	-Check magnet position -Check sensor wire
Display does not indicate door open	-Check magnet position -Check sensor wire
Door stops opening halfway	-Adjust overload setting
Door does not close	-Check for rubbing on floor and ceilings -Check the magnets and sensor wire -Check if the gearbox has tension
Electric strike does not release	-Check wiring -Check hardware -Check strike connection -Check strike voltage
Touch buttons do not respond	-Clean fingers or wipe the touch buttons

9. Universal Washroom Mode

- Normally is unlocked
- Install the door operator for required application based on installation instructions
- Adjust parameters for basic setup
- Follow the universal washroom wiring diagram to connect all the devices to proper terminals
- Once the devices are wired and door operator is programmed for basic setup, access the advanced settings to change operating mode of the controller

9.1 Parameters

Latch time: Change from 2 to 0

Control mode: Change from 1 to 2

Once the door is closed the display will say door closed (unoccupied)

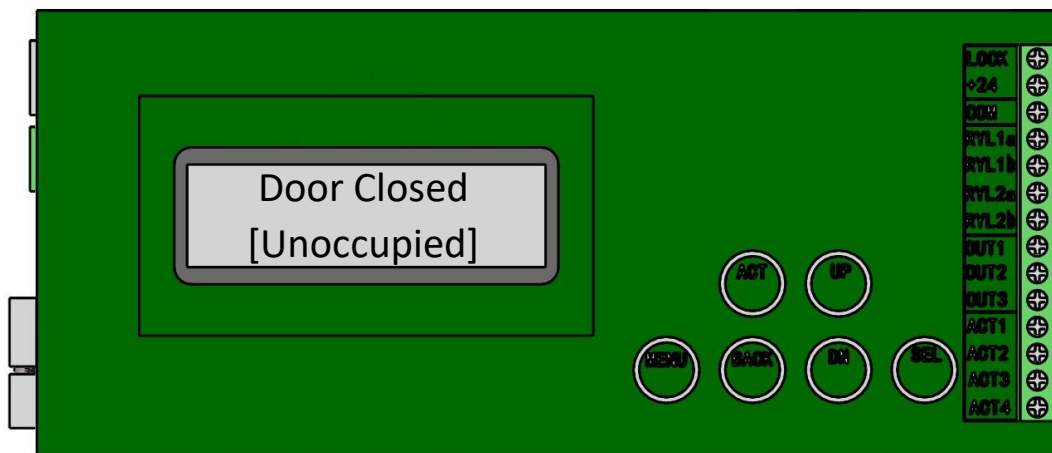

Fig 9.1.1

10. Access control mode

1. Install the door operator following instructions
2. Adjust parameters for basic setup
3. Follow to access control wiring diagram
4. Signal from access control panel needs to be dry to connect device and signal from access control panel to proper terminals.
5. Once devices are wired and the door operator is programmed for basic setup, access advanced settings to change operating mode of controller.

10.1 Parameters

- ✓ Control mode: Change from 1 to 3

- ✓ The display will say door closed (access denied)

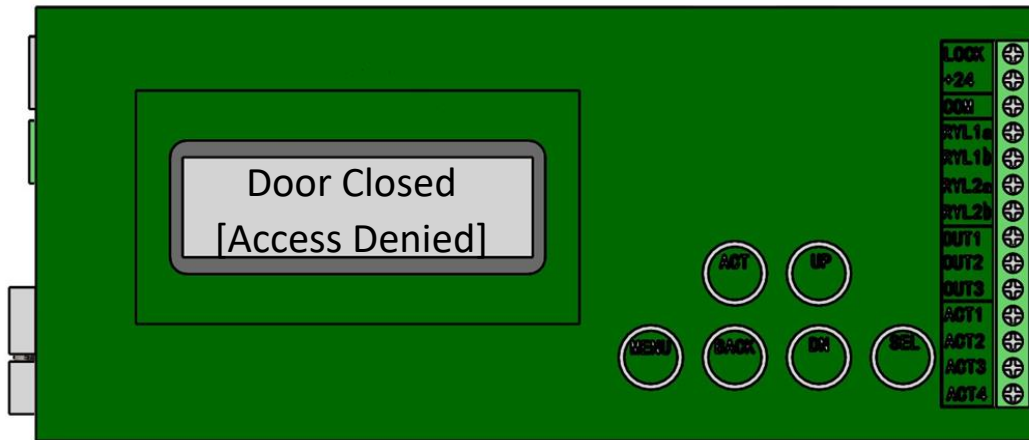

Fig 10.1.1

11. Advanced setting

To access the advanced setting, the basic setting needs to be set and door operator should run its learning cycle.

- ✓ Press menu touch to access menu

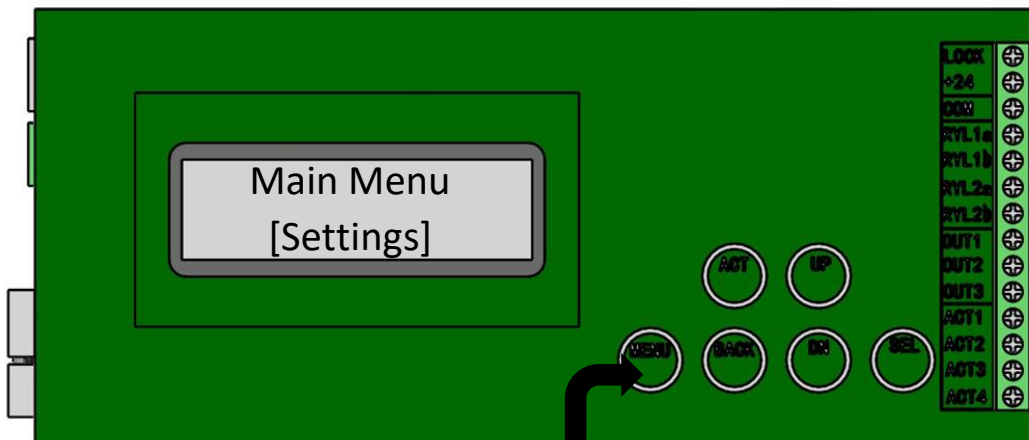

Fig 11.1

- ✓ Press SEL to reach settings

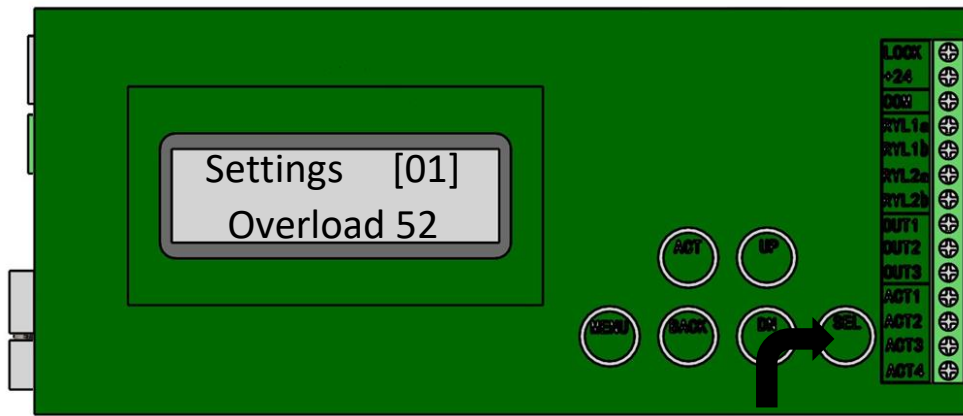

Fig 11.2

- ✓ Scroll up to parameter #10 (reactivate)

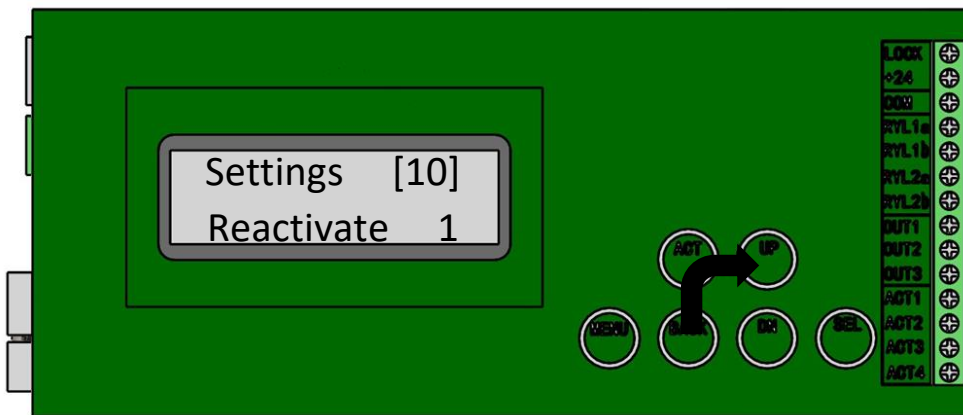

Fig 11.3

- ✓ In order to reach the upper menu, hold the up button and press menu button at the same time

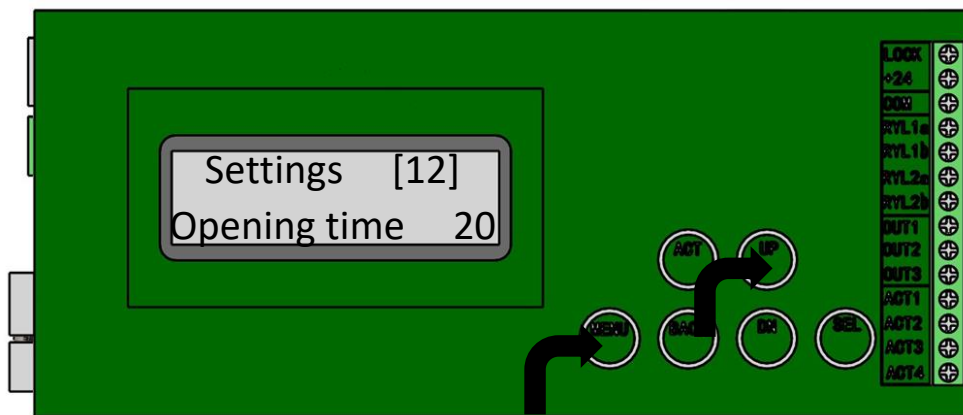

Fig 11.4

Then the display will show parameters to adjust desired setting.

Advanced setting are used for specific application of install such as access control universal washroom, motor revers on HD operator, opening or door exceeding 10 feet (adjustments and description of parameters can be found in parameters table).

12. Terminal description

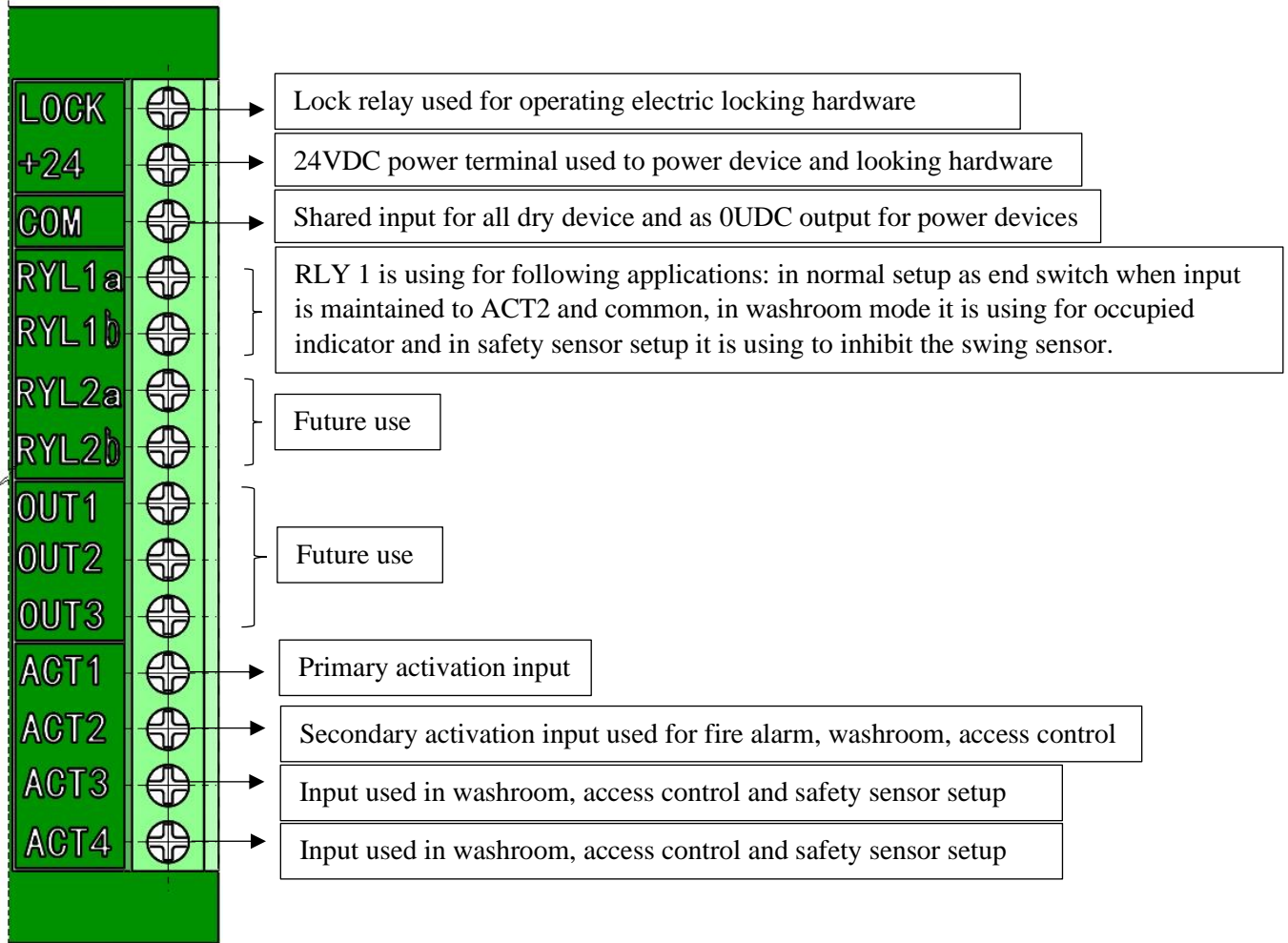

Fig 12.1

13. Re-Learn

1. Once the display indicate door closed press menu touch button and scroll down to calibrate. Press SEL touch button the display will indicate force relearn.
2. Press SEL touch button for relearn on next activation. Exit parameter mode when the display indicate door closed press act touch. Door operator will perform new learning.

14. Changes in software version

- V1.8- Standard ➡ Access control, washroom, motor revers
- V2.0- Safety Sensor ➡ Wiring diagram
- V2.3- Encoder, safety sensor, ACT DLY, preload time, preload speed, overload to 99 bypass.

15. Programming encoder and parameters

Install the operator based on the following instructions and use the required tools.

- ✓ Make sure door is in full closed position
- ✓ Menu → Calibrate display will indicate push ACT begin
- ✓ Press ACT touch button
- ✓ Manually push the fully open position, release the door to fully close and press SEL
- ✓ Set up the parameters following basic set up instructions
- ✓ Activate the door operator to perform learning cycle

❖ V2.3 beta-HD only

ACT DLY- Changed to delay between electric strike and door operator

Pre-load time- time now long will the door operator reverse before opening to release pressure on strike (used only HD)

Preload speed- Speed /force under which the door operator will reverse before opening to release pressure on strike (use only on HD)